

- English • Read Safety and Reference.
- Русский • Прочтите **Руководство по технике безопасности**.
- Українська • Прочитайте "**Правила безпеки та довідкова інформація**".
- Қазақша • **Қауіпсіздік нұсқаулығын** оқыңыз.
- O'zbekcha • Xavfsizlik bo'yicha ko'rsatmalar va havolalar'ni o'qib chiqing.
- Монгол • Аюулгүй ажиллагааны зааварчилгааг уншина уу.

⊕ : Depending on model / В зависимости от модели / Залежно від моделі / Үлгіге байланысты / Rusumiga qarab / Загвараас хамаарна

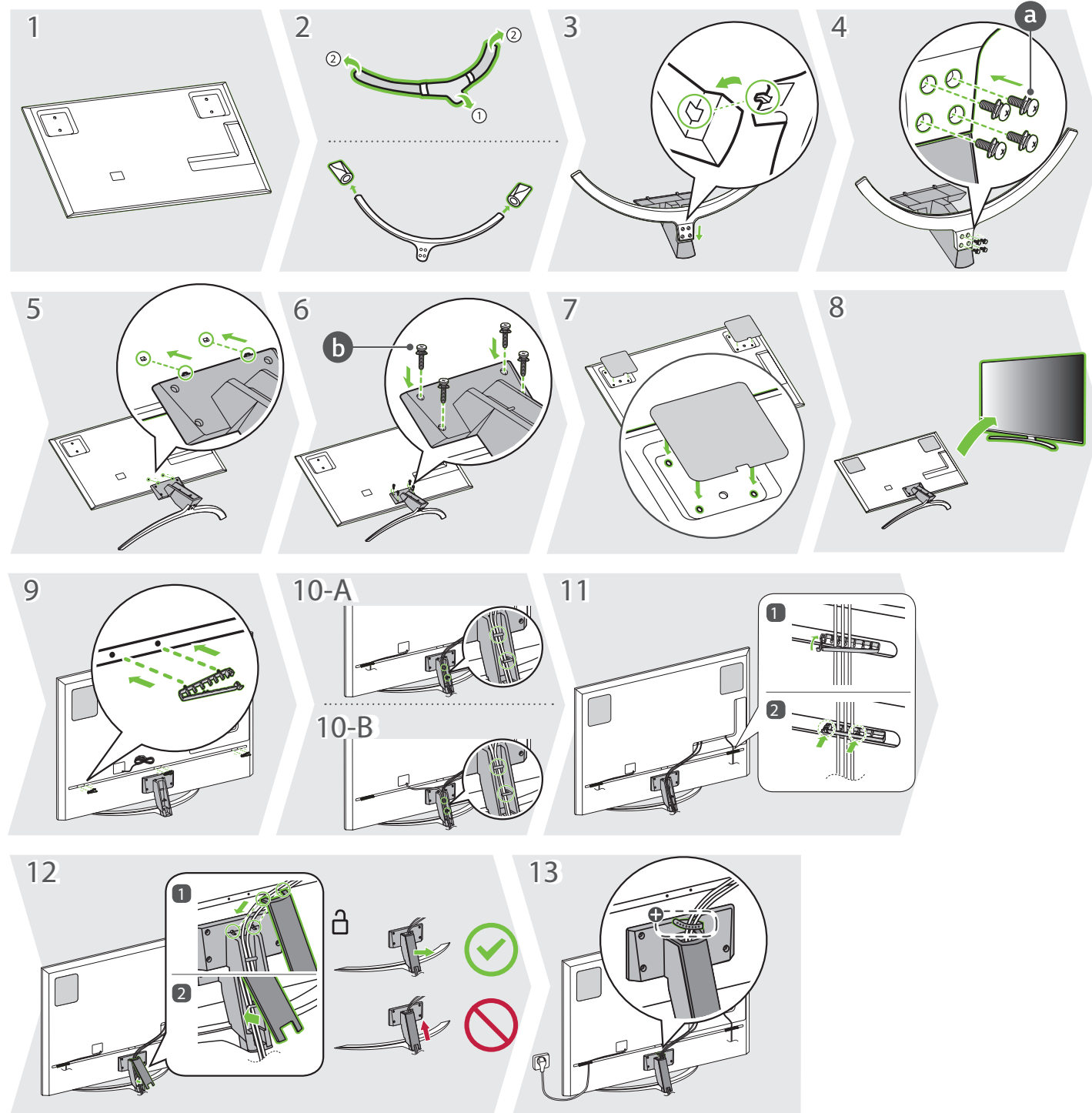



IR Blaster

Satellite IN

Satellite IN
Main

Satellite IN
Sub

ANTENNA/
CABLE IN

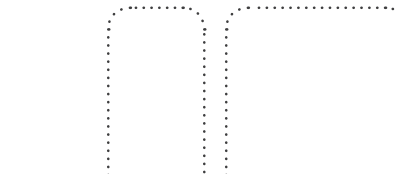

OPTICAL DIGITAL
AUDIO OUT

LAN

HDMI IN

USB IN

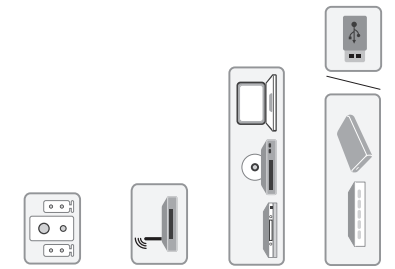
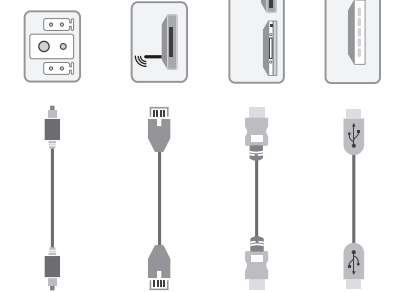

COMMON INTERFACE

USB IN

HDMI IN

HDMI IN
eARC/ARC

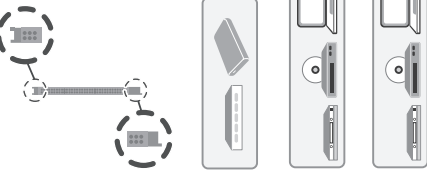
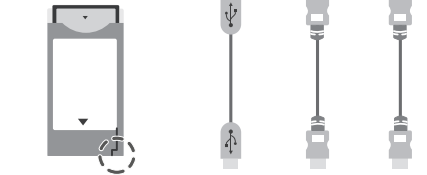

⊕ : Depending on model / В зависимости от модели / Залежно від моделі / Угліге байланысты / Русуміга цаgab / Загвараас хамгаарна

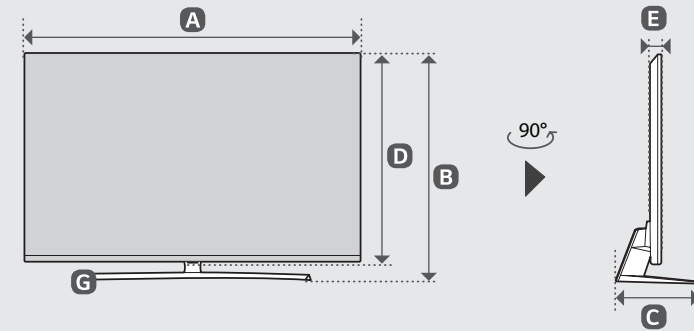

	A	B	C	D	E	F	F-G
	(mm)				(kg)		
75QNED963PA 75QNED966PA 75QNED969PA	1665	1032	405	958	29.5	40.8	37.4
75QNED993PB 75QNED996PB 75QNED999PB	1665	1032	405	958	29.5	40.8	37.4
Требования к электропитанию Вимоги до електроживлення Электрүтүгү шарттары				AC 100-240 V ~ 50 / 60 Hz			

